

# TRIG-TEK INC. ASSY 5095

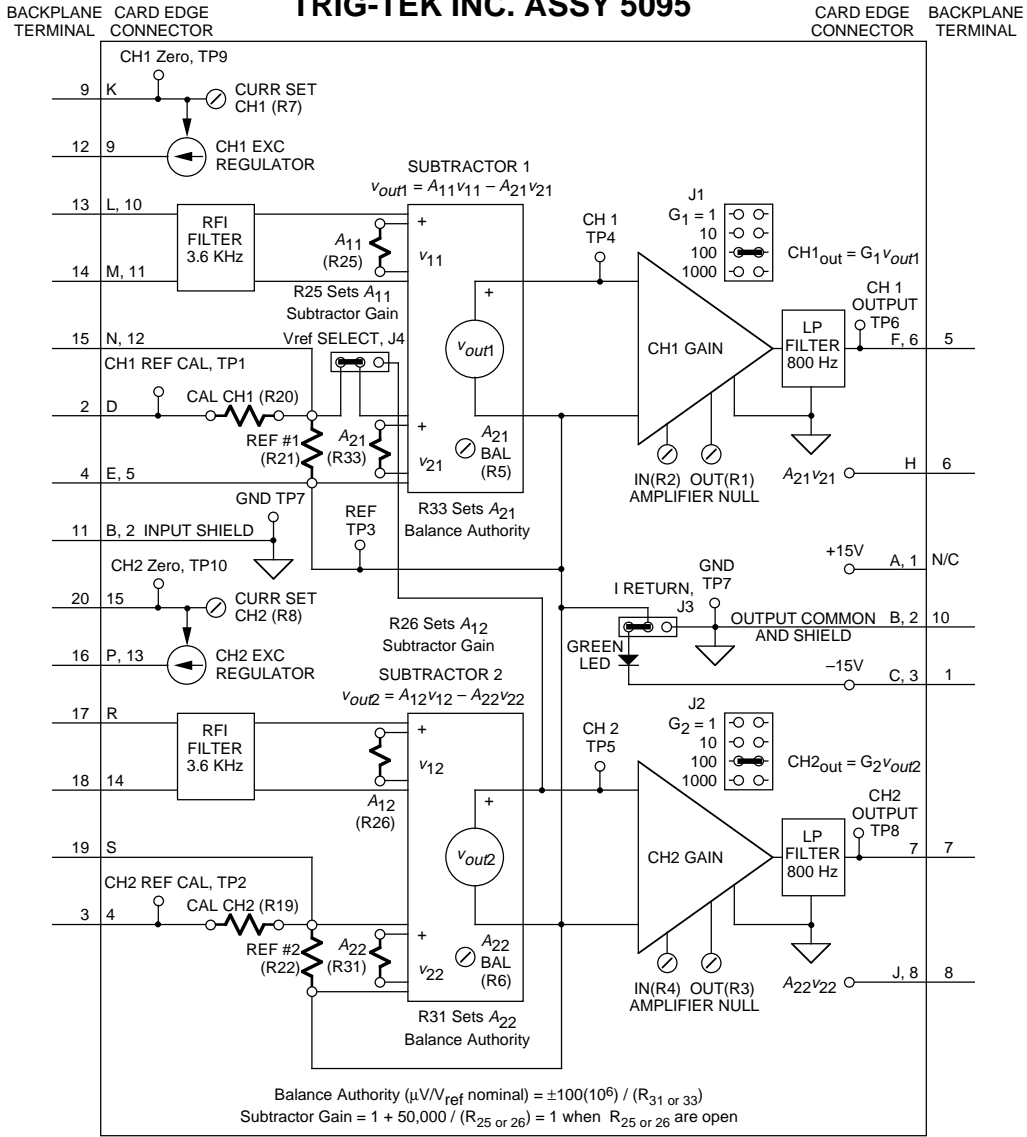

# TWO GAGES IN INDEPENDENT ANDERSON LOOPS USING TRIG-TEK INC. ASSY 5095

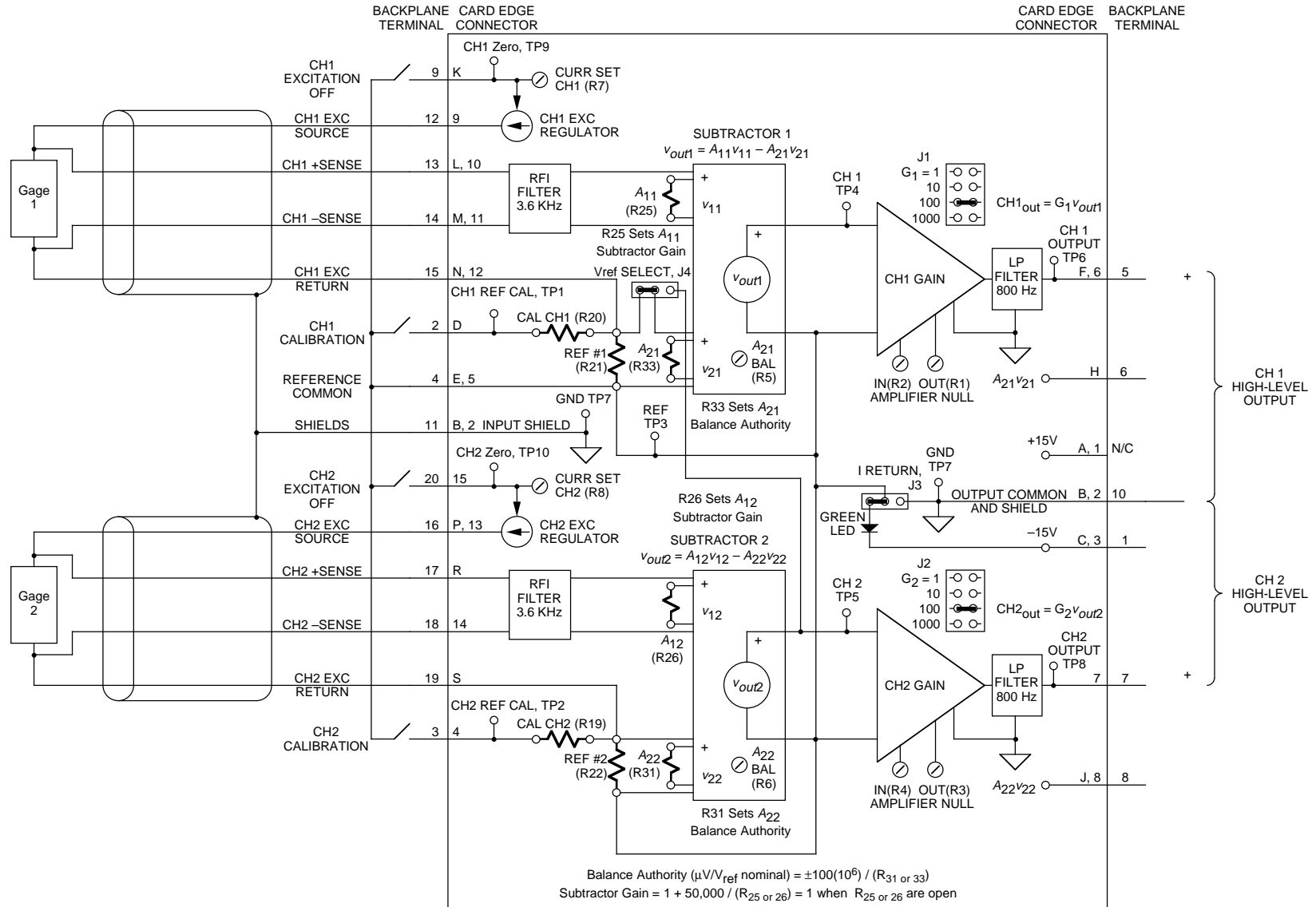



# MASTER CARD FOR FOUR INDEPENDENT GAGES IN ONE ANDERSON LOOP USING TRIG-TEK INC. ASSY 5095

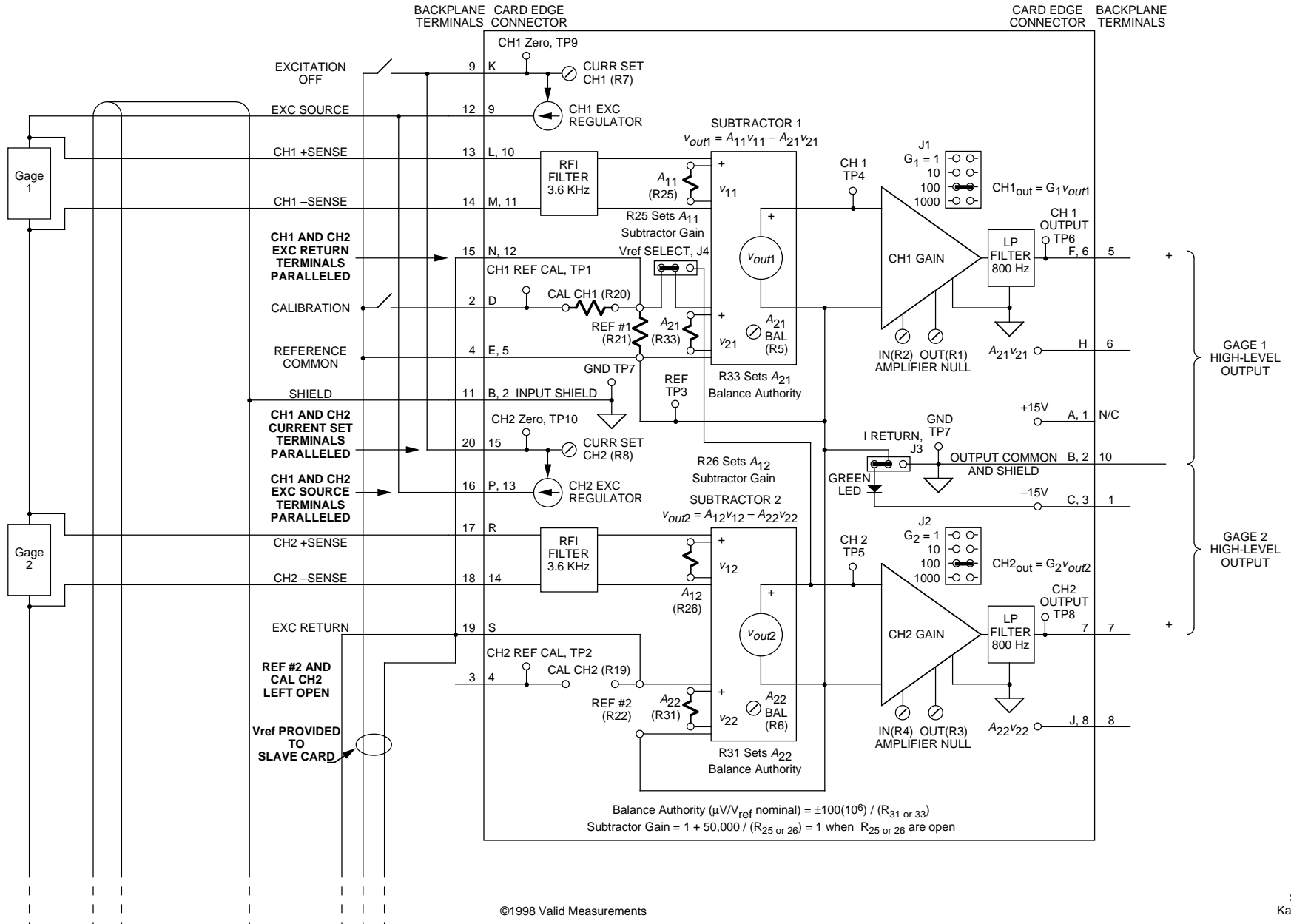

# SLAVE CARD FOR FOUR INDEPENDENT GAGES IN ONE ANDERSON LOOP USING TRIG-TEK INC. ASSY 5095

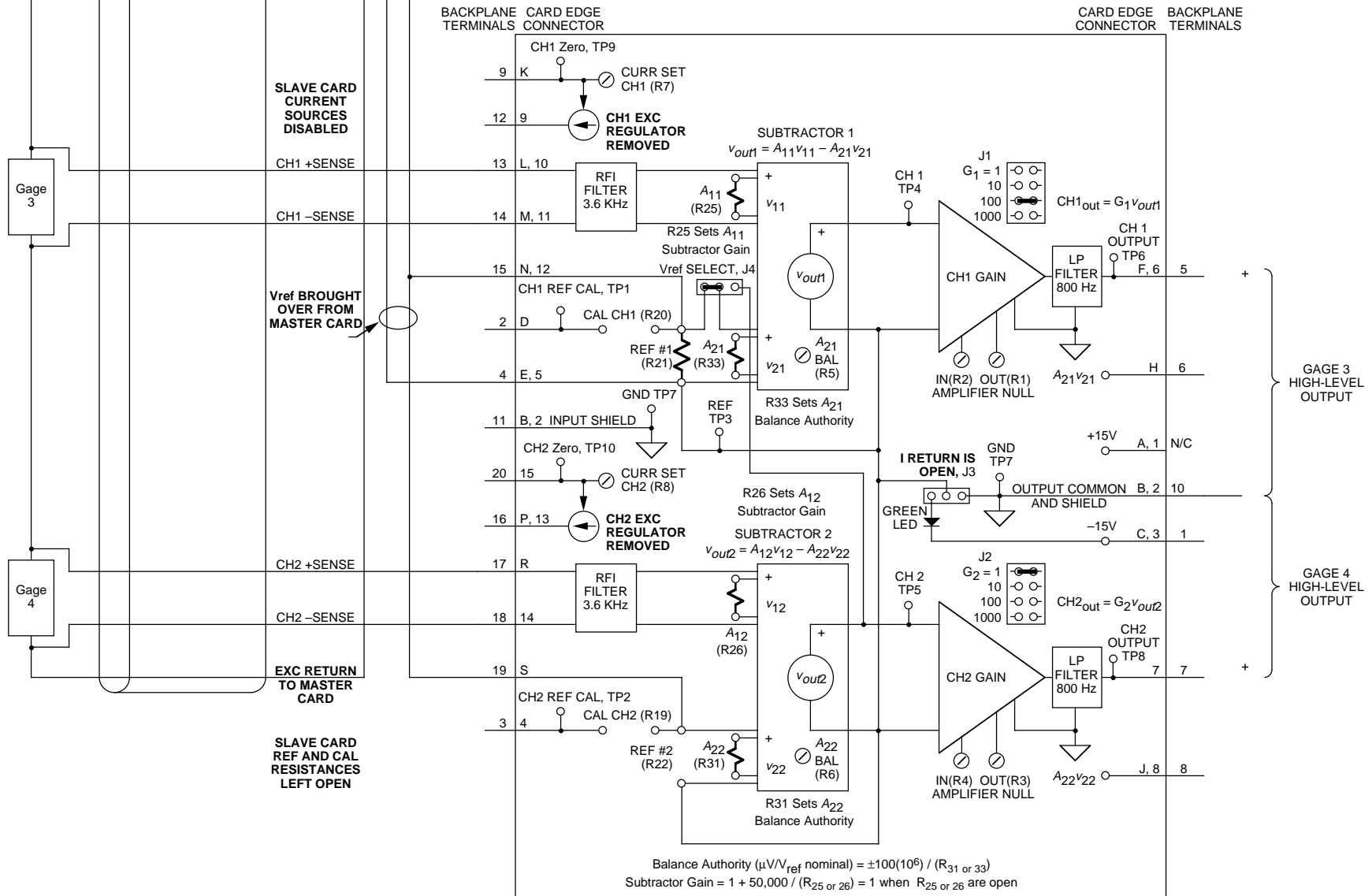

# TWO DIFFERENTIAL GAGES IN ONE ANDERSON LOOP USING TRIG-TEK INC. ASSY 5095

